

Alfa Laval DOC112 / DOC112HF

Brazed plate heat exchanger for oil cooling

Introduction

Alfa Laval DOC - Dedicated oil coolers are brazed plate heat exchangers with robust connection flanges, which are suitable for hydraulic oil cooling applications.

Applications

- Oil cooling

Benefits

- Compact
- Easy to install
- Self-cleaning
- Low level of service and maintenance is required
- All units are pressure and leak tested
- Gasket free
- Very robust connection flanges

Design

The brazing material seals and holds the plates together at the contact points ensuring optimal heat transfer efficiency and pressure resistance. Using advanced design technologies and extensive verification guarantees the highest performance and longest possible service life.

The robust connection flanges with internal threads and integrated mounting brackets are specifically designed for oil cooling under tough operating conditions and reduces costs because of easy installation. Additionally, the flanges allow significantly higher torque at installation than conventional connections.



Technical Data

Standard materials

Cover plates	Stainless steel
Connections	Stainless steel
Plates	Stainless steel
Brazing filler	Copper

Dimensions and weight ¹

A measure (mm)	16 + (2.07 * n)
A measure (inches)	0.63 + (0.08 * n)
Weight (kg) ²	4.82 + (0.35 * n)
Weight (lb) ²	10.63 + (0.77 * n)

¹ n = number of plates

² Excluding connections

Standard data

Volume per channel, litres (gal)	DOC112: 0.18 (0.0476) DOC112HF (S1-S2): 0.2 (0.0528) DOC112HF (S3-S4): 0.16 (0.0423)
Max. particle size, mm (inch)	1 (0.039)
Max. flowrate ¹ m ³ /h (gpm)	DOC112: 20 (88.1) DOC112HF: 37 (162.9)
Flow direction	Parallel
Min. number of plates	10
Max. number of plates	150

¹ Water at 5 m/s (16.4 ft/s) (connection velocity)

Dimensional drawing

Measurements in mm (inches)

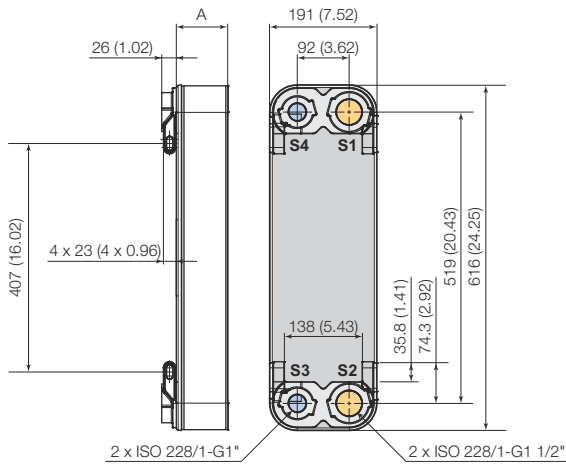

DOC112

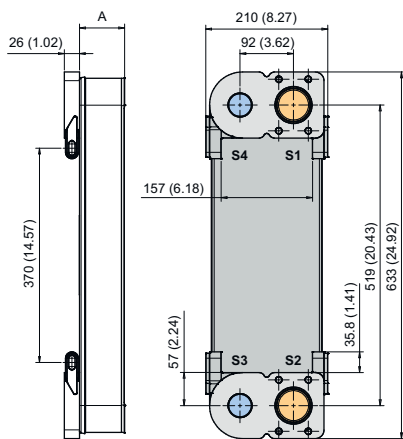

DOC112HF

Design pressure and temperature

DOC112/DOC112HF – PED approval pressure/temperature graph

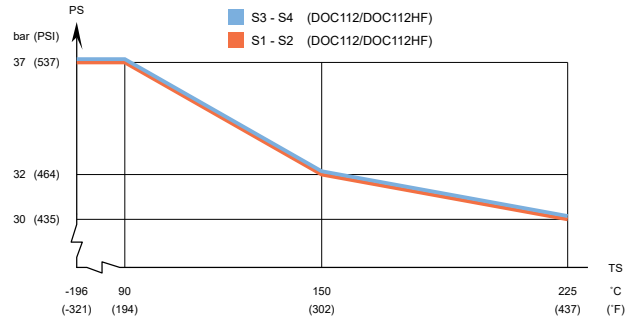

DOC112/DOC112HF – UL approval pressure/temperature graph

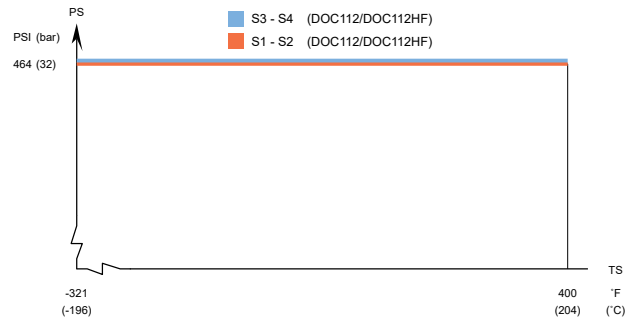

Designed for full vacuum.

Alfa Laval plate heat exchangers are available with a wide range of pressure vessel approvals. Please contact your Alfa Laval representative for more information.

NOTE: Values above are to be used as an indication. For exact values, please use the drawing generated by the Alfa Laval configurator or contact your local Alfa Laval representative.

This document and its contents are subject to copyrights and other intellectual property rights owned by Alfa Laval Corporate AB. No part of this document may be copied, re-produced or transmitted in any form or by any means, or for any purpose, without Alfa Laval Corporate AB's prior express written permission. Information and services provided in this document are made as a benefit and service to the user, and no representations or warranties are made about the accuracy or suitability of this information and these services for any purpose. All rights are reserved.

CHE00041-6-EN-GB

© Alfa Laval Corporate AB

How to contact Alfa Laval

Up-to-date Alfa Laval contact details for all countries are always available on our website at www.alfalaval.com