

Qty.	Description
1	<b>CM 3-6 A-R-G-V-AQQV C-A-A-N</b>
	
	<b>Note! Product picture may differ from actual product</b>
	Product No.: On request
	Compact, reliable, horizontal, multistage, end-suction centrifugal pump with axial suction port and radial discharge port. Pump materials in contact with the liquid are in high-grade stainless steel. The mechanical shaft seal is a special designed, unbalanced O-ring seal. Pipework connection is via internal Whitworth pipe threads, Rp (ISO 7/1).
	The pump is fitted with a 1-phase, foot-mounted, fan-cooled asynchronous motor.
	<b>Controls:</b>
	Frequency converter: NONE
	<b>Liquid:</b>
	Pumped liquid: Water
	Liquid temperature range: -20 .. 90 °C
	Selected liquid temperature: 20 °C
	Density: 998.2 kg/m <sup>3</sup>
	<b>Technical:</b>
	Pump speed on which pump data are based: 2900 rpm
	Rated flow: 3.1 m <sup>3</sup> /h
	Rated head: 41.53 m
	Code for shaft seal: AQQV
	Approvals: CE,EAC,UKCA
	Approvals for drinking water: WRAS,ACS,UBA
	Curve tolerance: ISO9906:2012 3B
	<b>Materials:</b>
	Pump housing: Stainless steel EN 1.4401 AISI 316
	Impeller: Stainless steel EN 1.4401 AISI 316
	<b>Installation:</b>
	Range of ambient temperature: -20 .. 55 °C
	Maximum operating pressure: 16 bar
	Max pressure at stated temp: 16 bar / 90 °C 16 bar / 90 °C
	Type of connection: Rp
	Size of inlet connection: 1 inch
	Size of outlet connection: 1 inch
	Outlet position: 12
	<b>Electrical data:</b>
	Motor standard: IEC
	Frame size: 80A
	Rated power - P2: 0.67 kW
	Mains frequency: 50 Hz
	Suitable for 50/60 Hz: N
	Rated voltage: 1 x 220-240 V V
	Service factor: 1.00
	Rated current: 4.4-4.0 A

Qty.	Description
1	<p>Starting current: 390-390 %  Rated speed: 2720-2800 rpm  Enclosure class (IEC 34-5): IP55  Insulation class (IEC 85): F  Built-in motor protection: PTO  Cable included (Yes/No): N</p> <p>Others:  Terminal box position: 12  Minimum efficiency index, MEI ≥: 0.7  Net weight: 15.1 kg  Gross weight: 17.6 kg  Country of origin: TW  Custom tariff no.: 84137042</p>

# On request CM 3-6 A-R-G-V-AQQV C-A-A-N 50 Hz

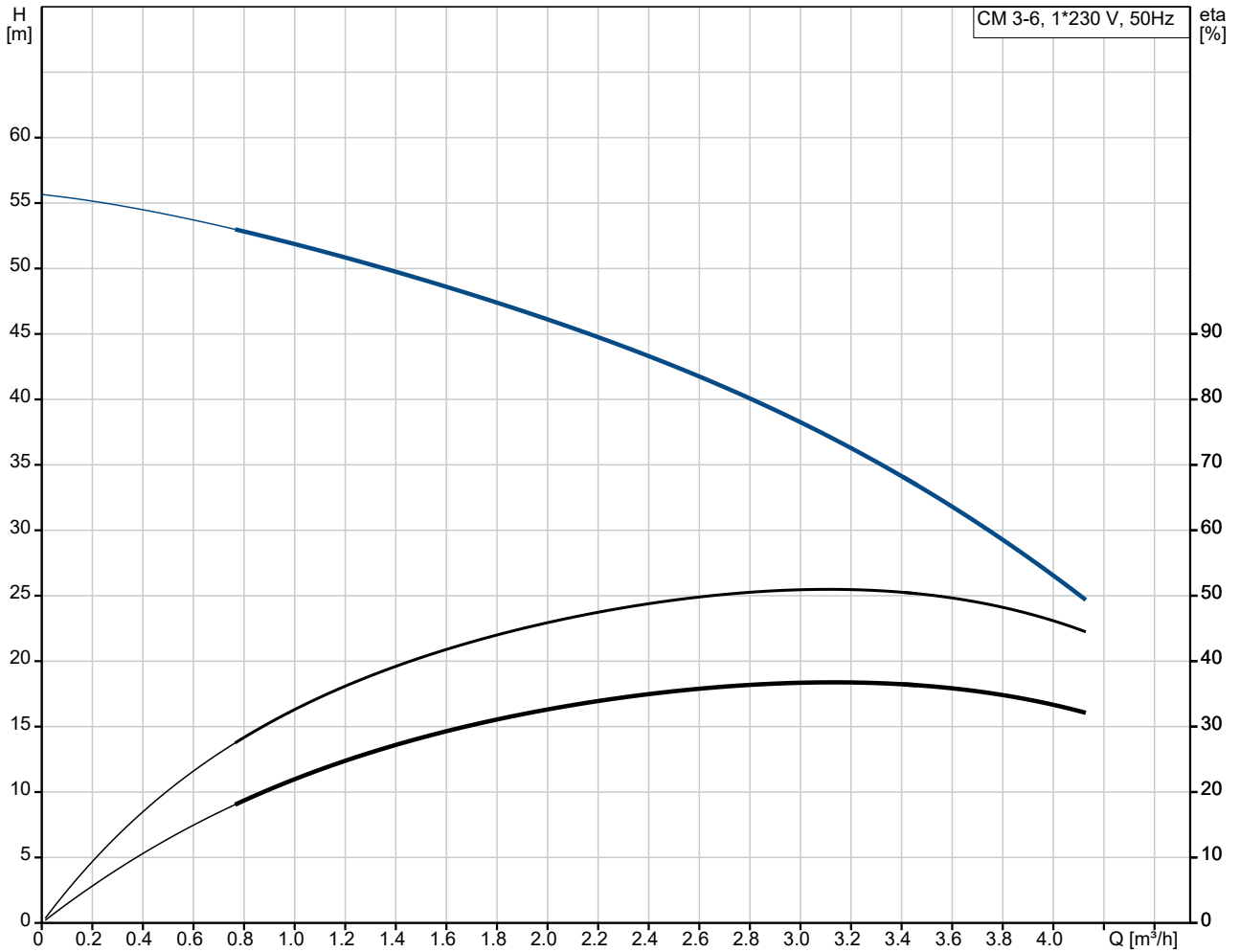

Pumped liquid = Water  
 Liquid temperature during operation = 20 °C  
 Density = 998.2 kg/m³

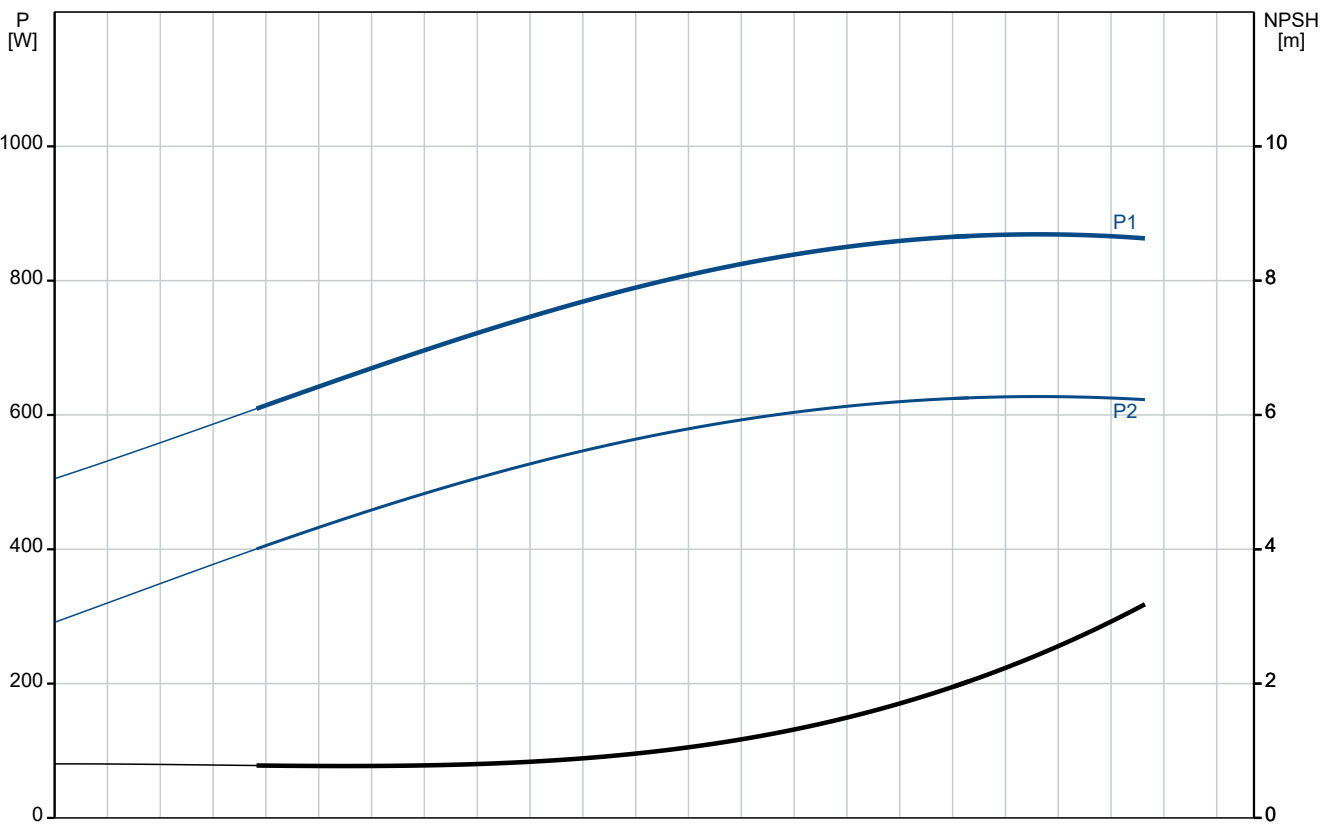

Description	Value
<b>General information:</b>	
Product name:	CM 3-6 A-R-G-V-AQQV C-A-A-N
Product No:	On request
EAN number:	On request
<b>Technical:</b>	
Pump speed on which pump data are based:	2900 rpm
Rated flow:	3.1 m <sup>3</sup> /h
Rated head:	41.53 m
Impellers:	6
Code for shaft seal:	AQQV
Approvals:	CE,EAC,UKCA
Approvals for drinking water:	WRAS,ACS,UBA
Curve tolerance:	ISO9906:2012 3B
Pump version:	A
Model:	A
<b>Materials:</b>	
Pump housing:	Stainless steel
Pump housing:	EN 1.4401
Pump housing:	AISI 316
Impeller:	Stainless steel
Impeller:	EN 1.4401
Impeller:	AISI 316
Material code:	G
Code for rubber:	V
<b>Installation:</b>	
Range of ambient temperature:	-20 .. 55 °C
Maximum operating pressure:	16 bar
Max pressure at stated temp:	16 bar / 90 °C
Max pressure at stated temp:	16 bar / 90 °C
Type of connection:	Rp
Size of inlet connection:	1 inch
Size of outlet connection:	1 inch
Outlet position:	12
Connect code:	R
<b>Liquid:</b>	
Pumped liquid:	Water
Liquid temperature range:	-20 .. 90 °C
Selected liquid temperature:	20 °C
Density:	998.2 kg/m <sup>3</sup>
<b>Electrical data:</b>	
Motor standard:	IEC
Frame size:	80A
Rated power - P2:	0.67 kW
Mains frequency:	50 Hz
Suitable for 50/60 Hz:	N
Rated voltage:	1 x 220-240 V V
Service factor:	1.00
Rated current:	4.4-4.0 A
Starting current:	390-390 %
Rated speed:	2720-2800 rpm
Enclosure class (IEC 34-5):	IP55
Insulation class (IEC 85):	F
Built-in motor protection:	PTO
Cable included (Yes/No):	N
<b>Controls:</b>	
Frequency converter:	NONE
<b>Others:</b>	
Terminal box position:	12
Minimum efficiency index, MEI ≥:	0.7
Net weight:	15.1 kg
Gross weight:	17.6 kg
Country of origin:	TW

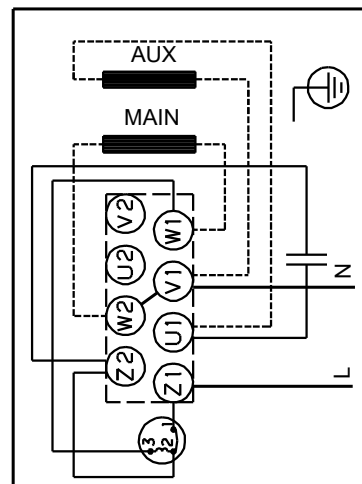
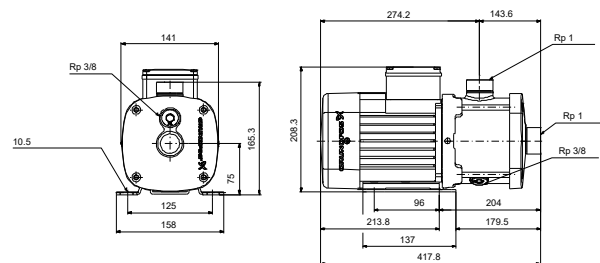
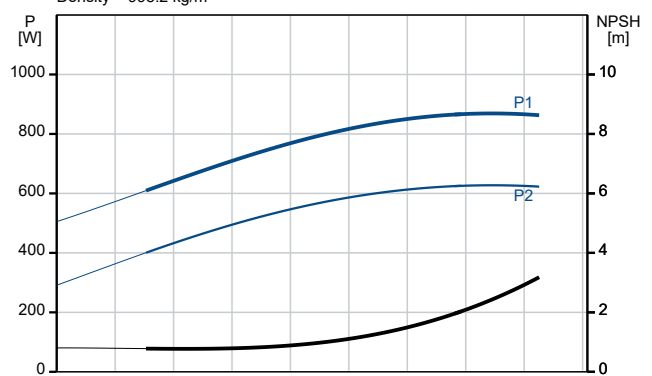
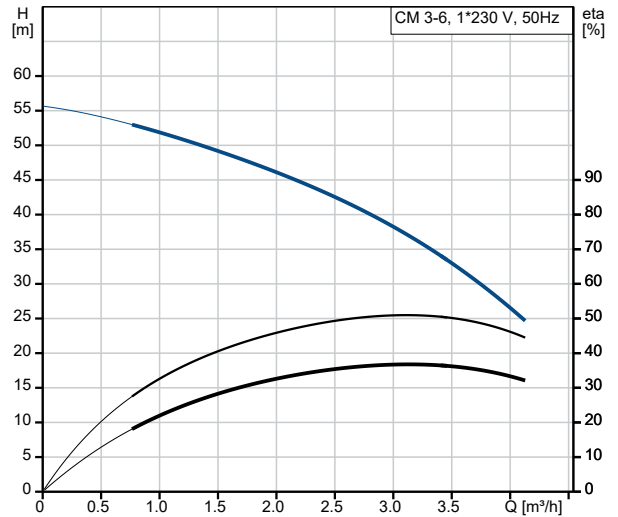

**Description****Value**

Custom tariff no.:

84137042

# On request CM 3-6 A-R-G-V-AQQV C-A-A-N 50 Hz

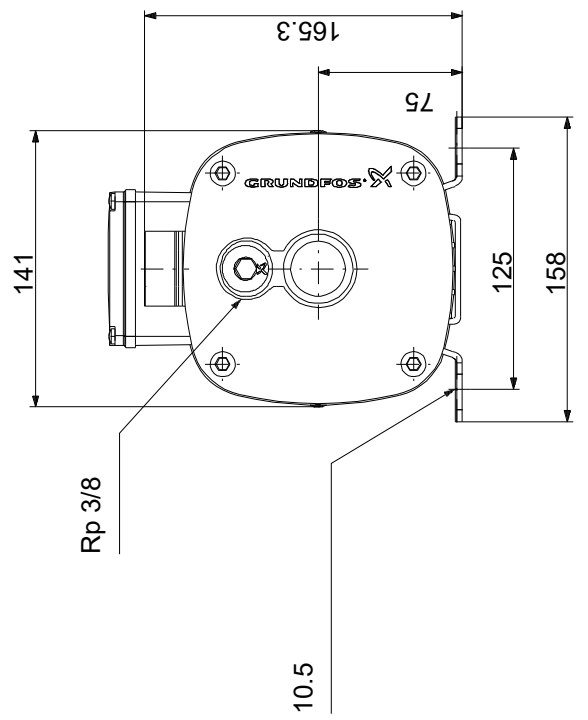
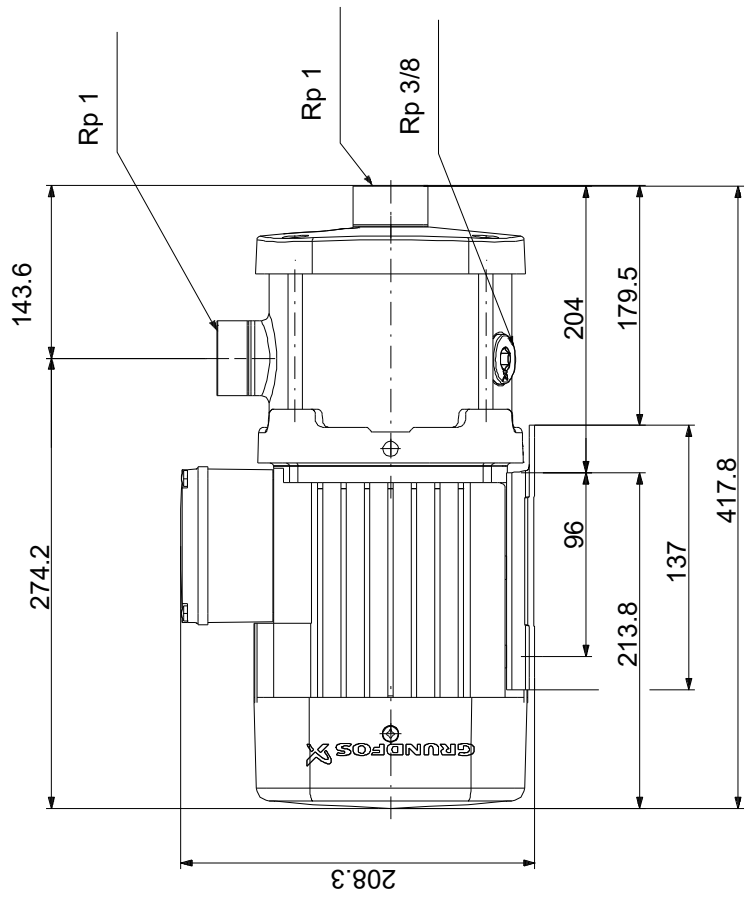

Note! All units are in [mm] unless others are stated.  
 Disclaimer: This simplified dimensional drawing does not show all details.